



# SERVICE PARTS LIST

**BULLETIN NO.**  
54-38-6133

SPECIFY CATALOG NO. AND SERIAL NO. WHEN ORDERING PARTS		REVISED BULLETIN	DATE
<b>4.5" (115mm) ANGLE GRINDER</b>		54-38-6132	Apr. 2015
<b>CATALOG NO.</b>	<b>6130-33</b>	<b>WIRING INSTRUCTION</b>	
<b>STARTING SERIAL NO.</b>	<b>C27D</b>	<b>SEE PAGE 3</b>	

FIG.	PART NO.	DESCRIPTION OF PART	NO. REQ.
★ 1	14-30-0155	Gearcase Assembly	(1)
2	05-88-1200	M4 x 16 Pan Hd. Plastite T-20 Screw	(7)
★ 3	14-73-0055	5/8-11 Spindle/Hub Assembly	(1)
★ 4	34-80-0210	Retaining Ring	(1)
5	06-82-2380	#8-32 x 1/2" Pan Hd. Slit. Tapt. T-20 Screw	(6)
7	05-55-0620	Nut	(1)
8	32-60-0275	Bevel Pinion	(1)
10	-----	Armature	(1)
12	42-96-0177	Rubber Bearing Cup	(1)
13	06-82-3002	Pan Hd. Taptite T-10 ST Screw	(4)

FIG.	PART NO.	DESCRIPTION OF PART	NO. REQ.
★ 34	34-40-0270	O-Ring	(1)
★ 35	-----	Spindle Lock Pin	(1)
36	42-40-0025	Bushing	(1)
37	-----	Bevel Gear	(1)
38	-----	Gearcase	(1)
★ 39	-----	5/8-11 Spindle	(1)
★ 40	44-86-0155	Retaining Plate	(1)
★ 50	16-10-0120	Armature Assembly	(1)
★ 52	49-96-0130	Spanner Wrench	(1)
★ 53	34-40-0330	O-Ring	(1)
★ 54	-----	Ball Bearing	(1)
★ 55	-----	Spring Pin	(1)
★ 56	05-90-0225	Spring Washer	(1)
★ 57	40-50-0780	Spring	(1)
★ 58	44-20-0065	Locking Tang	(1)
★ 59	05-81-0020	M3 x 6 Philips #2 Taptite Screw	(1)
★ 60	44-40-0215	5/8-11 Outer Disk Flange	(1)
★ 61	44-40-0245	5/8-11 Inner Disk Flange	(1)
★ 62	43-54-0155	4.5" T27 Guard (Standard)	(1)
★	43-54-0185	4.5" T1 Guard (Not Shown) (Optional)	(1)
	42-62-0110	Side Handle (Not Shown)	(1)

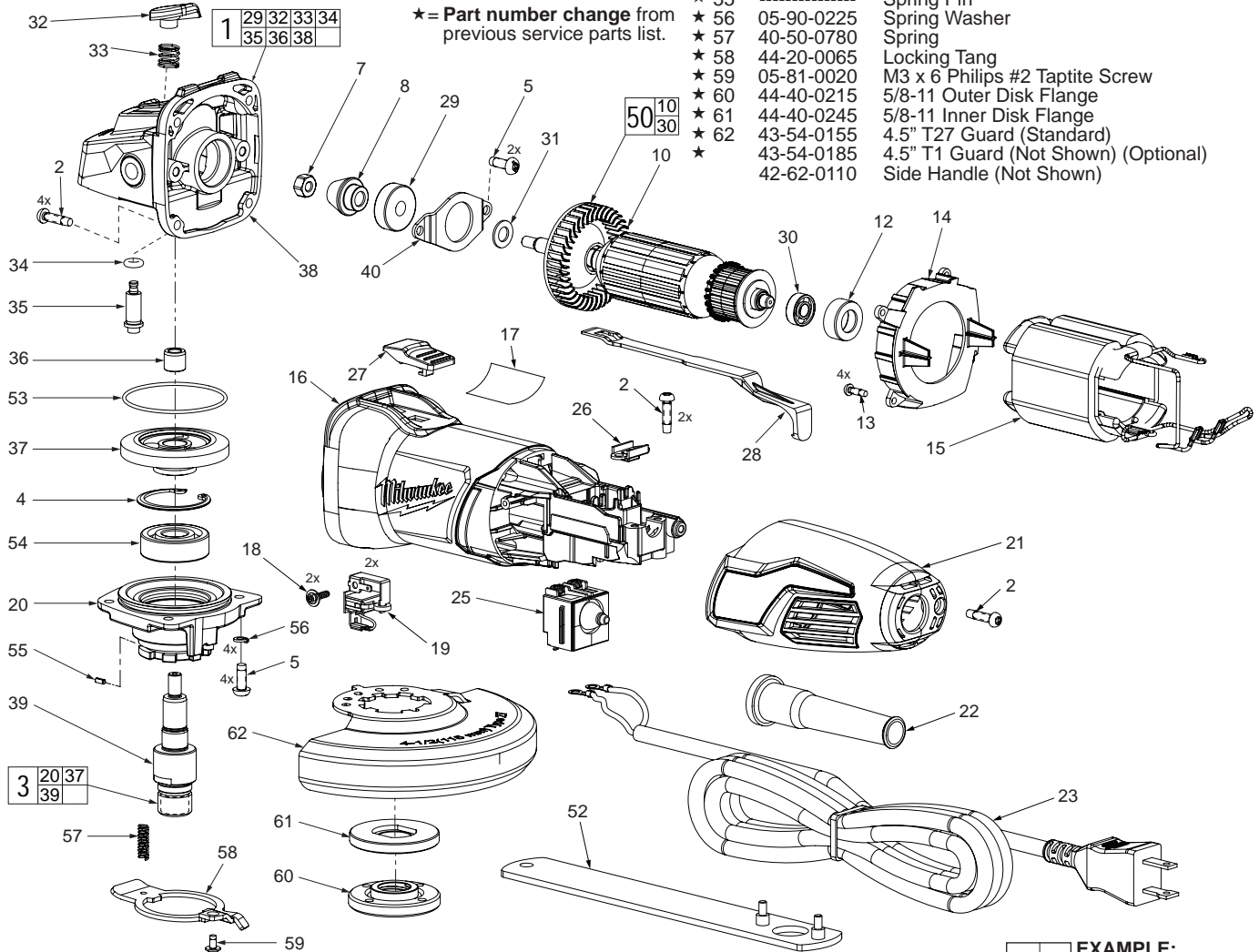

★ = Part number change from previous service parts list.

FIG.	PART NO.	DESCRIPTION OF PART	NO. REQ.
★ 14	42-14-0035	Baffle	(1)
★ 15	18-07-0176	Service Field Assembly	(1)
★ 16	31-50-0261	Motor Housing	(1)
★ 17	12-20-0105	Service Nameplate Kit	(1)
18	05-88-1100	M3 x 10 Pan Hd. T-10 Screw	(2)
★ 19	22-22-0085	Carbon Brush Assembly	(2)
★ 20	-----	Lower Gearcase Hub	(1)
★ 21	31-44-0795	Rear Handle	(1)
22	44-76-0210	Cord Protector	(1)
23	22-64-0565	Cordset	(1)
25	23-66-0385	Switch	(1)
26	31-17-0040	Cord Clamp	(1)
★ 27	31-92-0075	Slide Switch Button	(1)
★ 28	31-92-0065	Slide Pole	(1)
29	-----	Ball Bearing	(1)
30	02-04-0110	Ball Bearing	(1)
31	45-88-1995	Flat Washer	(1)
★ 32	-----	Spindle Lock Button	(1)
33	40-50-1330	Spring	(1)

**EXAMPLE:**  

00	0
----	---

 Component Parts (Small #) Are Included When Ordering The Assembly (Large #).

**\* LUBRICATION NOTE:** When servicing the Gears (8 & 37) or the Gearcase (38), 90-95% of the old grease must be removed prior to new grease being added.

**FIG. LUBRICATION** (\*See lubrication note above):

- 8,37 Type "Y" Grease, No. 49-08-5270, Must Be Applied To All Gear Teeth.
- 4,38 Lightly coat with grease Retaining Ring and bearing bore in Gearcase.
- 38 .4 Ounces (13 Grams) Type "Y" Grease, No. 49-08-5270.

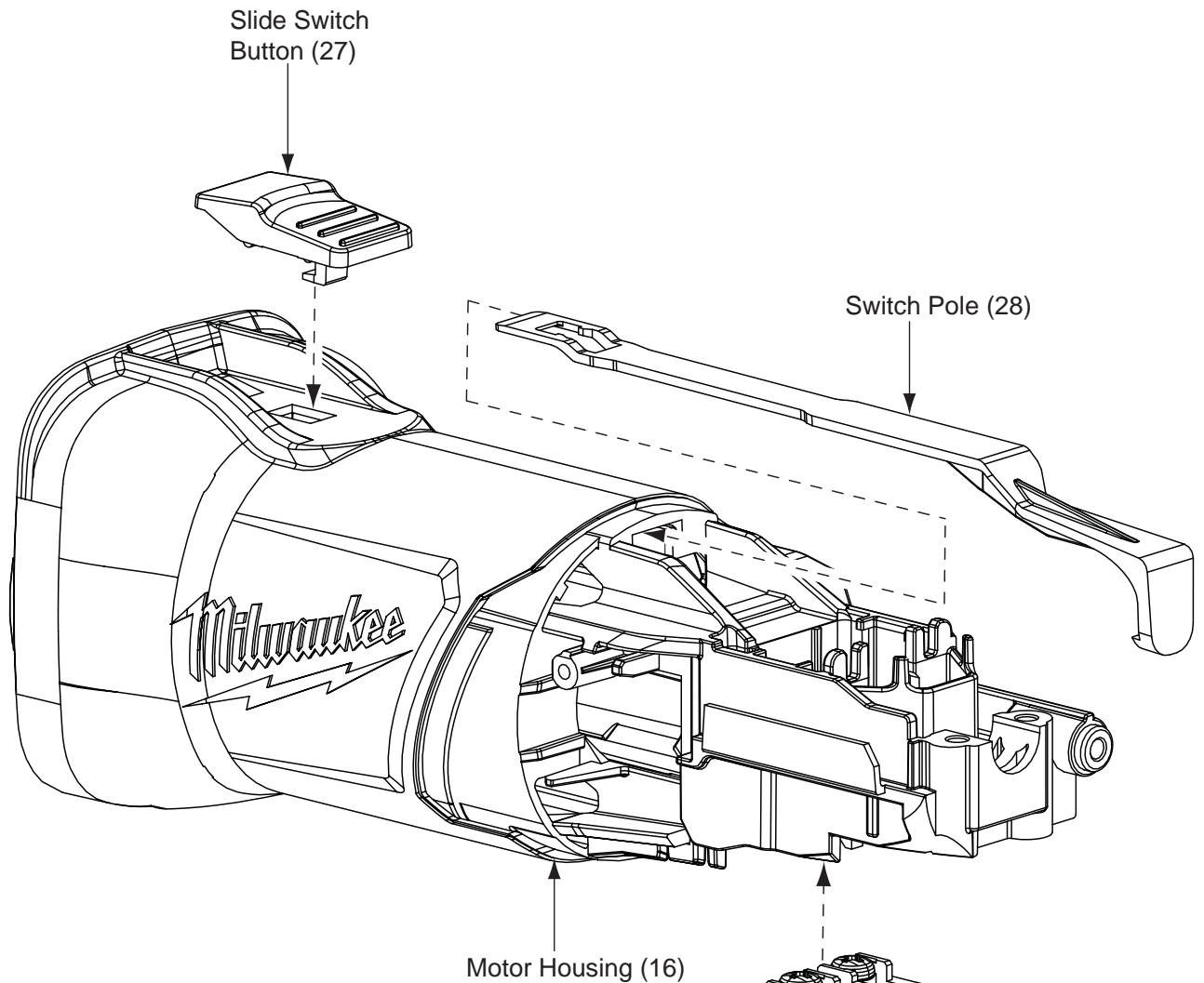

To remove Slide Switch Button (27), position a flat blade screwdriver along the center of the gearcase (38). Place blade under the locking tab of the Switch Blade Button and gently pry upward.

Be sure that push button of the Switch (25) is placed into the corresponding recess of the Switch Pole (28).

When reassembling the Slide Switch Button (27) be sure to orient with the locking tab as shown, towards the gearcase (38).

When servicing the Motor Housing (16) or the Switch Pole (28) it is recommended to snap the Slide Switch Button (27) into the Switch Pole, as shown prior to installing the Field (15).

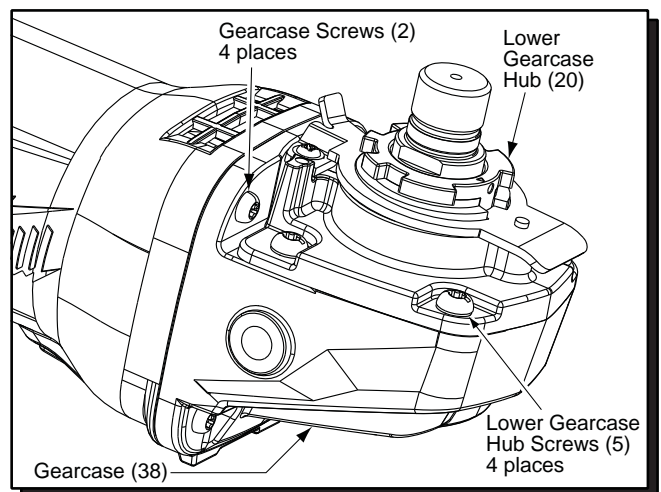
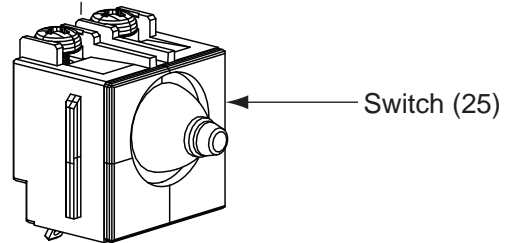

When servicing the Gearcase (38), first remove the four Screws (5) and Lower Gearcase Hub (20) to prevent damage to the bottom two Screws (2) that secure the Gearcase.

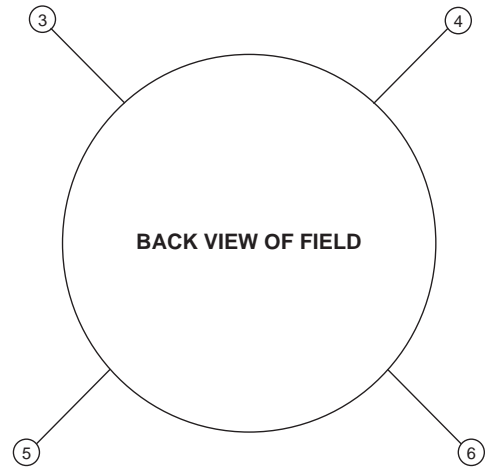
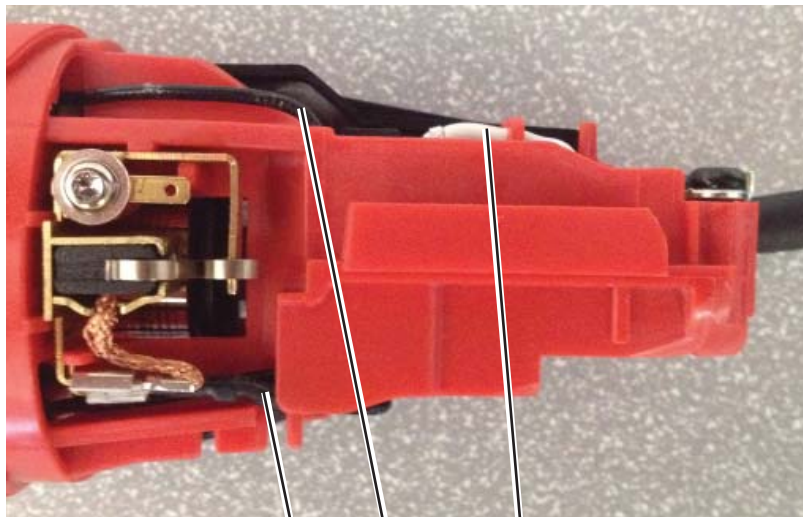
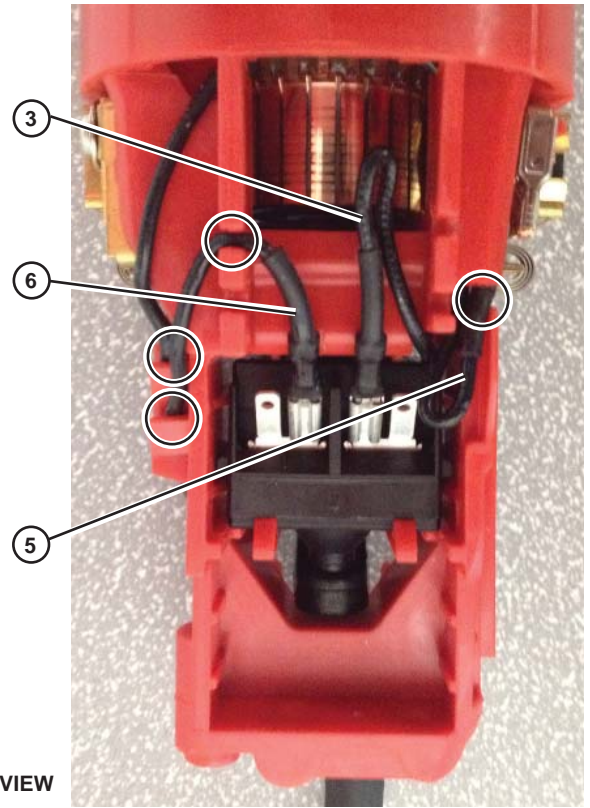
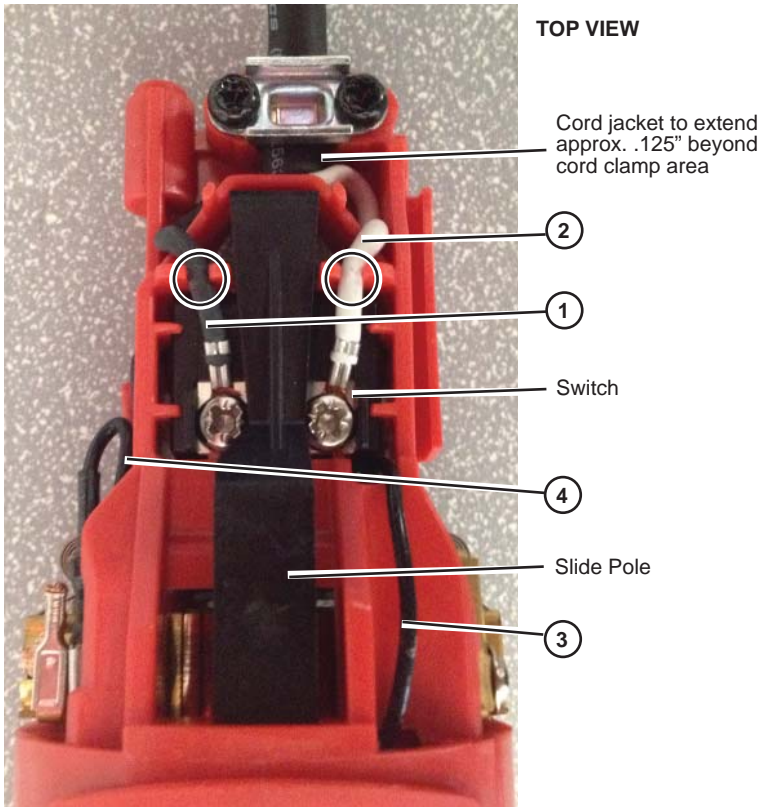

**LEFT VIEW**

**RIGHT VIEW**

AS AN AID TO REASSEMBLY, TAKE NOTICE OF WIRE ROUTING AND POSITION IN WIRE GUIDES AND TRAPS WHILE DISMANTLING TOOL.

BE CAREFUL AND AVOID PINCHING WIRES BETWEEN HANDLE HALVES WHEN ASSEMBLING.

○ = WIRE TRAPS

